

3.3 V/5 V ECL 9-Bit Shift Register

MC100EP142

Description

The MC100EP142 is a 9-bit shift register, designed with byte-parity applications in mind. The MC100EP142 is capable of performing serial/parallel data into serial/parallel out and shifting in only one direction. The nine inputs D0 – D8 accept parallel input data, while S-IN accepts serial input data. The QT0:87 outputs do not need to be terminated for the shift operation to function. To minimize power, any Q output not used should be left unterminated.

The SEL (Select) input pin is used to switch between the two modes of operation – SHIFT and LOAD. The shift direction is from Bit 0 to Bit 8. Input data is accepted by the registers a set-up time before the positive going edge of CLK0 or CLK1; shifting is also accomplished on the positive clock edge. A HIGH on the Master Reset pin (MR) asynchronously resets all the registers to zero, overriding CLK0 and CLK1 inputs.

The 100 Series contains temperature compensation.

Features

- Shift Frequency >2.8 GHz (Typical)
- 9-Bit for Byte-Parity Applications
- Asynchronous Master Reset
- Dual Clocks
- PECL Mode Operating Range: $V_{CC} = 3.0\text{ V}$ to 5.5 V with $V_{EE} = 0\text{ V}$
- NECL Mode Operating Range: $V_{CC} = 0\text{ V}$ with $V_{EE} = -3.0\text{ V}$ to -5.5 V
- Open Input Default State
- Safety Clamp on Inputs
- These Devices are Pb-Free and are RoHS Compliant



ON Semiconductor®

www.onsemi.com

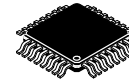

LQFP-32
FA SUFFIX
CASE 561AB

MARKING DIAGRAM*

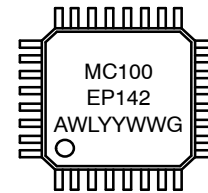

A = Assembly Location
WL = Wafer Lot
YY = Year
WW = Work Week
G = Pb-Free Package

(Note: Microdot may be in either location)
*For additional marking information, refer to Application Note [AND8002/D](#).

ORDERING INFORMATION

Device	Package	Shipping
MC100EP142FAG	LQFP-32 (Pb-Free)	250 Units / Tray

MC100EP142

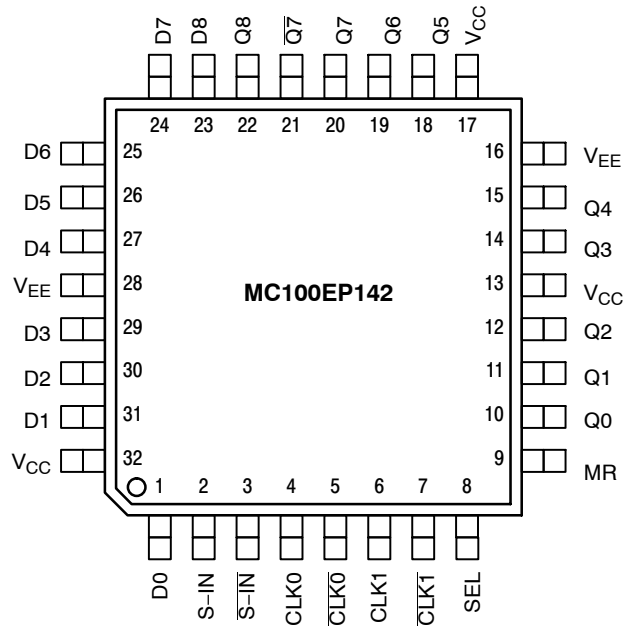

Figure 1. Pinout: LQFP-32 (Top View)

Table 1. PIN DESCRIPTION

Pin	Name	I/O	Default State	Description
1,31,30,29,27,26,25,24,23	D[0:8]	ECL Input	Low	Single-Ended Parallel Data Inputs [0:8]. Internal 75 kΩ to V _{EE} .
2	S-IN	ECL Input	Low	Noninverted Differential Serial Input. Internal 75 kΩ to V _{EE} .
3	S-IN	ECL Input	High	Inverted Differential Serial Input. Internal 75 kΩ to V _{EE} and 36.5 kΩ to V _{CC} .
4	CLK0	ECL Input	Low	Noninverted Differential CLK0 Input. Internal 75 kΩ to V _{EE} .
5	CLK0	ECL Input	High	Inverted Differential CLK0B Input. Internal 75 kΩ to V _{EE} and 36.5 kΩ to V _{CC} .
6	CLK1	ECL Input	Low	Noninverted Differential CLK1 Input. Internal 75 kΩ to V _{EE} .
7	CLK1	ECL Input	High	Inverted Differential CLK1B Input. Internal 75 kΩ to V _{EE} and 36.5 kΩ to V _{CC} .
8	SEL	ECL Input	Low	Single-Ended Select Logic Input. Internal 75 kΩ to V _{EE} .
9	MR	ECL Input	Low	Single-Ended Master Reset Logic Input. Internal 75 kΩ to V _{EE} .
10,11,12,14,15,18,19,22	Q0,Q1,Q2,Q3,Q4,Q5,Q6,Q8	ECL Output	-	Single-Ended parallel Data outputs [0,1,2,3,4,5,6,8]. Typically Terminated with 50 Ω to V _{TT} = V _{CC} - 2 V.
13,17,32	V _{CC}	-	-	Positive supply Voltage. All V _{CC} Pins must be Externally Connected to Power Supply to Guarantee Proper Operation.
16,28	V _{EE}	-	-	Negative supply Voltage. All V _{EE} Pins must be Externally connected to Power Supply to Guarantee Proper Operation.
20	Q7	ECL Output	-	Noninverted Differential parallel/Serial Data Output 7. Typically Terminated with 50 Ω to V _{TT} = V _{CC} - 2 V.
21	Q7	ECL Output	-	Inverted Differential parallel/Serial Data Output 7. Typically Terminated with 50 Ω to V _{TT} = V _{CC} - 2 V.

1. All V_{CC} and V_{EE} pins must be externally connected to Power Supply to guarantee proper operation.

MC100EP142

Table 2. TRUTH TABLE

Function (Note 2)	SEL	S-IN	MR	CLK0	CLK1	Q0	Q1	Q2	Q3	Q4	Q5	Q6	Q7	Q8	Q9
Load	L	X	L	Z	Z	D0	D1	D2	D3	D4	D5	D6	D7	D8	D9
Shift	H	L	L	Z	Z	L	Q0	Q1	Q2	Q3	Q4	Q5	Q6	Q7	Q8
	H	H	L	Z	Z	H	Q0	Q1	Q2	Q3	Q4	Q5	Q6	Q7	Q8
Reset	X	X	H	Z	Z	L	L	L	L	L	L	L	L	L	L

2. All Load and Shift functions are accomplished on the positive edge of CLK0 or CLK1.

MC100EP142

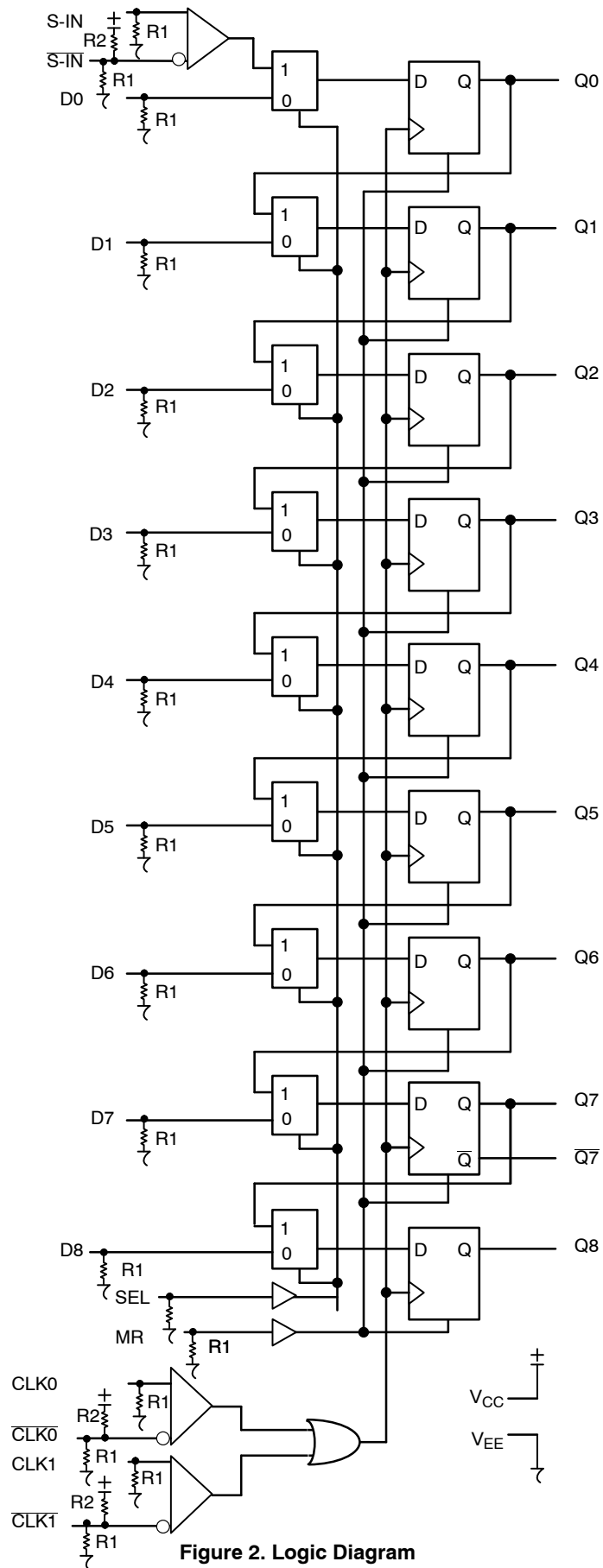

Figure 2. Logic Diagram

MC100EP142

Table 3. ATTRIBUTES

Characteristics	Value
Internal Input Pulldown Resistor (R1)	75 kΩ
Internal Input Pullup Resistor (R2)	37.5 kΩ
ESD Protection Human Body Model Machine Model Charged Device Model	> 2 kV > 100 V > 2 kV
Moisture Sensitivity (Note 3) LQFP-32	Level 2
Flammability Rating Oxygen Index: 28 to 34	UL-94 V-0 @ 0.125 in
Transistor Count	405 Devices
Meets or exceeds JEDEC Spec EIA/JESD78 IC Latchup Test	

3. For additional information, refer to Application Note [AND8003/D](#).

Table 4. MAXIMUM RATINGS

Symbol	Parameter	Condition 1	Condition 2	Rating	Unit
V _{CC}	Positive Power Supply	V _{EE} = 0 V		8	V
V _{EE}	Negative Power Supply	V _{CC} = 0 V		-8	V
V _I	PECL Mode Input Voltage NECL Mode Input Voltage	V _{EE} = 0 V V _{CC} = 0 V	V _I ≤ V _{CC} V _I ≥ V _{EE}	6 -6	V
I _{out}	Output Current	Continuous Surge		50 100	mA
T _A	Operating Temperature Range			-40 to +85	°C
T _{stg}	Storage Temperature Range			-65 to +150	°C
θ _{JA}	Thermal Resistance (Junction-to-Ambient)	0 lfpm 500 lfpm	LQFP-32 LQFP-32	80 55	°C/W
θ _{JC}	Thermal Resistance (Junction-to-Case)	Standard Board	LQFP-32	12 to 17	°C/W
T _{sol}	Wave Solder Pb-Free	≤ 3 sec @ 260°C		265	°C

Stresses exceeding those listed in the Maximum Ratings table may damage the device. If any of these limits are exceeded, device functionality should not be assumed, damage may occur and reliability may be affected.

MC100EP142

Table 5. 100EP DC CHARACTERISTICS, PECL $V_{CC} = 3.3\text{ V}$, $V_{EE} = 0\text{ V}$ (Note 4)

Symbol	Characteristic	-40°C			25°C			85°C			Unit
		Min	Typ	Max	Min	Typ	Max	Min	Typ	Max	
I_{EE}	Negative Power Supply Current	105	125	145	105	130	150	105	130	150	mA
V_{OH}	Output HIGH Voltage (Note 5)	2155	2280	2405	2155	2280	2405	2155	2280	2405	mV
V_{OL}	Output LOW Voltage (Note 5)	1305	1480	1605	1305	1480	1605	1305	1480	1605	mV
V_{IH}	Input HIGH Voltage (Single-Ended)	2075		2420	2075		2420	2075		2420	mV
V_{IL}	Input LOW Voltage (Single-Ended)	1305		1675	1305		1675	1305		1675	mV
V_{IHCMR}	Input HIGH Voltage Common Mode Range (Differential Configuration) (Note 6)	2.0		3.3	2.0		3.3	2.0		3.3	V
I_{IH}	Input HIGH Current (@ V_{IH})			150			150			150	μA
I_{IL}	Input LOW Current (@ V_{IL}) CLK0, CLK1, D, S-IN CLK0, CLK1, S-IN	0.5 -150			0.5 -150			0.5 -150			μA

NOTE: Device will meet the specifications after thermal equilibrium has been established when mounted in a test socket or printed circuit board with maintained transverse airflow greater than 500 lpm.

- Input and output parameters vary 1:1 with V_{CC} . V_{EE} can vary +0.3 V to -2.2 V.
- All loading with $50\ \Omega$ to $V_{CC} - 2.0\text{ V}$.
- V_{IHCMR} min varies 1:1 with V_{EE} . V_{IHCMR} max varies 1:1 with V_{CC} . The V_{IHCMR} range is referenced to the most positive side of the differential input signal.

MC100EP142

Table 6. 100EP DC CHARACTERISTICS, PECL $V_{CC} = 5.0\text{ V}$, $V_{EE} = 0\text{ V}$ (Note 7)

Symbol	Characteristic	-40°C			25°C			85°C			Unit
		Min	Typ	Max	Min	Typ	Max	Min	Typ	Max	
I_{EE}	Negative Power Supply Current (Note 8)	105	125	145	105	130	150	105	130	150	mA
V_{OH}	Output HIGH Voltage (Note 9)	3855	3980	4105	3855	3980	4105	3855	3980	4105	mV
V_{OL}	Output LOW Voltage (Note 9)	3005	3180	3305	3005	3180	3305	3005	3180	3305	mV
V_{IH}	Input HIGH Voltage (Single-Ended)	3775		4120	3775		4120	3775		4120	mV
V_{IL}	Input LOW Voltage (Single-Ended)	3005		3375	3005		3375	3005		3375	mV
V_{IHCMR}	Input HIGH Voltage Common Mode Range (Differential Configuration) (Note 10)	2.0		5.0	2.0		5.0	2.0		5.0	V
I_{IH}	Input HIGH Current (@ V_{IH})			150			150			150	μA
I_{IL}	Input LOW Current (@ V_{IL}) CLK0, CLK1, D, S-IN CLK0, CLK1, S-IN	0.5 -150			0.5 -150			0.5 -150			μA

NOTE: Device will meet the specifications after thermal equilibrium has been established when mounted in a test socket or printed circuit board with maintained transverse airflow greater than 500 lfm.

7. Input and output parameters vary 1:1 with V_{CC} . V_{EE} can vary +2.0 V to -0.5 V.

8. Required 500 lfm air flow when using +5 V power supply. For $(V_{CC} - V_{EE}) > 3.3\text{ V}$, 5 Ω to 10 Ω in line with V_{EE} required for maximum thermal protection at elevated temperatures. Recommend $V_{CC} - V_{EE}$ operation at $\leq 3.3\text{ V}$.

9. All loading with 50 Ω to $V_{CC} - 2.0\text{ V}$.

10. V_{IHCMR} min varies 1:1 with V_{EE} , V_{IHCMR} max varies 1:1 with V_{CC} . The V_{IHCMR} range is referenced to the most positive side of the differential input signal.

Table 7. 100EP DC CHARACTERISTICS, NECL $V_{CC} = 0\text{ V}$, $V_{EE} = -5.5\text{ V}$ to -3.0 V (Note 11)

Symbol	Characteristic	-40°C			25°C			85°C			Unit
		Min	Typ	Max	Min	Typ	Max	Min	Typ	Max	
I_{EE}	Negative Power Supply Current (Note 12)	105	125	145	105	130	150	105	130	150	mA
V_{OH}	Output HIGH Voltage (Note 13)	-1145	-1020	-895	-1145	-1020	-895	-1145	-1020	-895	mV
V_{OL}	Output LOW Voltage (Note 13)	-1995	-1820	-1695	-1995	-1820	-1695	-1995	-1820	-1695	mV
V_{IH}	Input HIGH Voltage (Single-Ended)	-1225		-880	-1225		-880	-1225		-880	mV
V_{IL}	Input LOW Voltage (Single-Ended)	-1995		-1625	-1995		-1625	-1995		-1625	mV
V_{IHCMR}	Input HIGH Voltage Common Mode Range (Differential Configuration) (Note 14)	$V_{EE}+2.0$		0.0	$V_{EE}+2.0$		0.0	$V_{EE}+2.0$		0.0	V
I_{IH}	Input HIGH Current (@ V_{IH})			150			150			150	μA
I_{IL}	Input LOW Current (@ V_{IL}) CLK0, CLK1, D, S-IN CLK0, CLK1, S-IN	0.5 -150			0.5 -150			0.5 -150			μA

NOTE: Device will meet the specifications after thermal equilibrium has been established when mounted in a test socket or printed circuit board with maintained transverse airflow greater than 500 lfm.

11. Input and output parameters vary 1:1 with V_{CC} .

12. Required 500 lfm air flow when using -5 V power supply. For $(V_{CC} - V_{EE}) > 3.3\text{ V}$, 5 Ω to 10 Ω in line with V_{EE} required for maximum thermal protection at elevated temperatures. Recommend $V_{CC} - V_{EE}$ operation at $\leq 3.3\text{ V}$.

13. All loading with 50 Ω to $V_{CC} - 2.0\text{ V}$.

14. V_{IHCMR} min varies 1:1 with V_{EE} , V_{IHCMR} max varies 1:1 with V_{CC} . The V_{IHCMR} range is referenced to the most positive side of the differential input signal.

MC100EP142

Table 8. AC CHARACTERISTICS $V_{CC} = 3.0\text{ V to }5.5\text{ V}$; $V_{EE} = 0.0\text{ V or }V_{CC} = 0.0\text{ V}$; $V_{EE} = -3.0\text{ V to }-5.5\text{ V}$ (Note 15)

Symbol	Characteristic	-40°C			25°C			85°C			Unit
		Min	Typ	Max	Min	Typ	Max	Min	Typ	Max	
f_{SHIFT}	Maximum Shift Frequency					2.8					GHz
t_{PLH} , t_{PHL}	Propagation Delay to Output CLKx MR	500 500	625 625	750 750	550 550	675 675	800 800	575 575	700 700	825 825	ps
t_s	Setup Time D SEL	50 100	-50 50		50 100	-50 50		50 100	-50 50		ps
t_h	Hold Time D SEL	100 50	50 -50		100 50	50 -50		100 50	50 -50		ps
t_{RR}	Reset Recovery Time					800					ps
t_{pw}	Minimum Pulse Width					200					ps
t_{SKEW}	Within-Device Skew (Note 16) Duty Cycle Skew (Note 17) Q, \bar{Q}		50 5.0	100 20		50 5.0	100 20		50 5.0	100 20	ps
t_{JITTER}	Random Clock Jitter (Figure 3)		1	2		1	2		1	2	ps
V_{inpp}	Input Voltage Swing/Sensitivity (Differential Configuration)	150	800	1200	150	800	1200	150	800	1200	mV
t_r , t_f	Rise/Fall Times @ 50 MHz (20 - 80%)	110	180	250	125	190	275	150	215	300	ps

NOTE: Device will meet the specifications after thermal equilibrium has been established when mounted in a test socket or printed circuit board with maintained transverse airflow greater than 500 lpm.

15. Measured using a 750 mV source, 50% duty cycle clock source. All loading with 50 Ω to $V_{CC} - 2.0\text{ V}$.

16. Within-device skew is defined as identical transitions on similar paths through a device.

17. Skew is measured between outputs under identical transitions. Duty cycle skew is defined only for differential operation when the delays are measured from the cross point of the inputs to the cross point of the outputs.

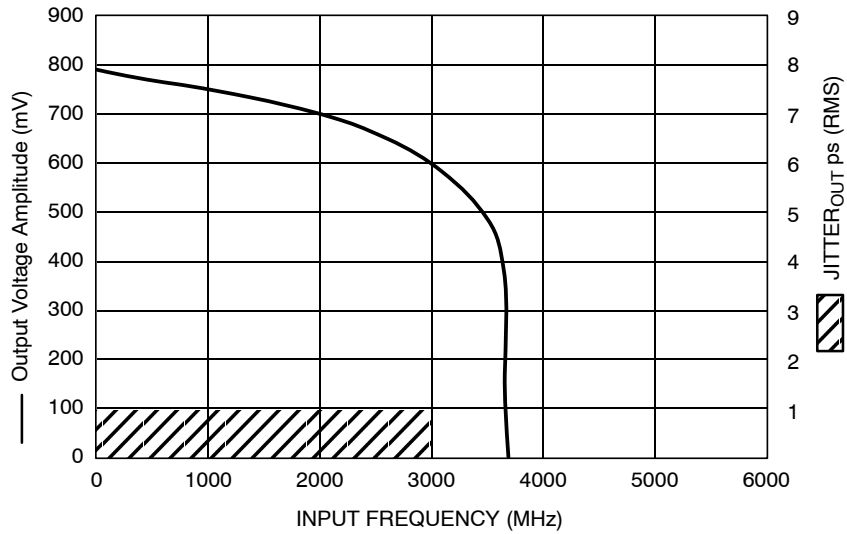

Figure 3. Output Voltage Amplitude / RMS Jitter vs. Input Frequency at Ambient Temperature (Typical)

MC100EP142

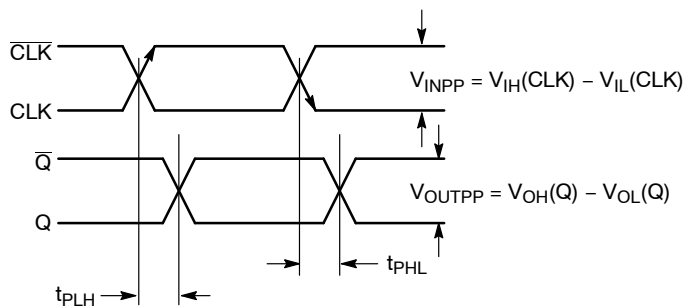

Figure 4. AC Reference Measurement

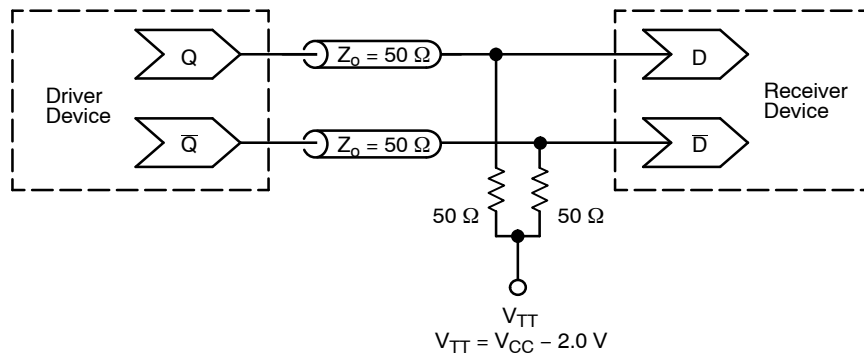

Figure 5. Typical Termination for Output Driver and Device Evaluation
(See Application Note [AND8020/D](#) – Termination of ECL Logic Devices.)

Resource Reference of Application Notes

- AN1405/D – ECL Clock Distribution Techniques
- AN1406/D – Designing with PECL (ECL at +5.0 V)
- AN1503/D – ECLinPS™ I/O SPICE Modeling Kit
- AN1504/D – Metastability and the ECLinPS Family
- AN1568/D – Interfacing Between LVDS and ECL
- AN1672/D – The ECL Translator Guide
- AND8001/D – Odd Number Counters Design
- AND8002/D – Marking and Date Codes
- AND8020/D – Termination of ECL Logic Devices
- AND8066/D – Interfacing with ECLinPS
- AND8090/D – AC Characteristics of ECL Devices

MECHANICAL CASE OUTLINE
PACKAGE DIMENSIONS

ON Semiconductor®



LQFP-32, 7x7
CASE 561AB-01
ISSUE O

DATE 19 JUN 2008

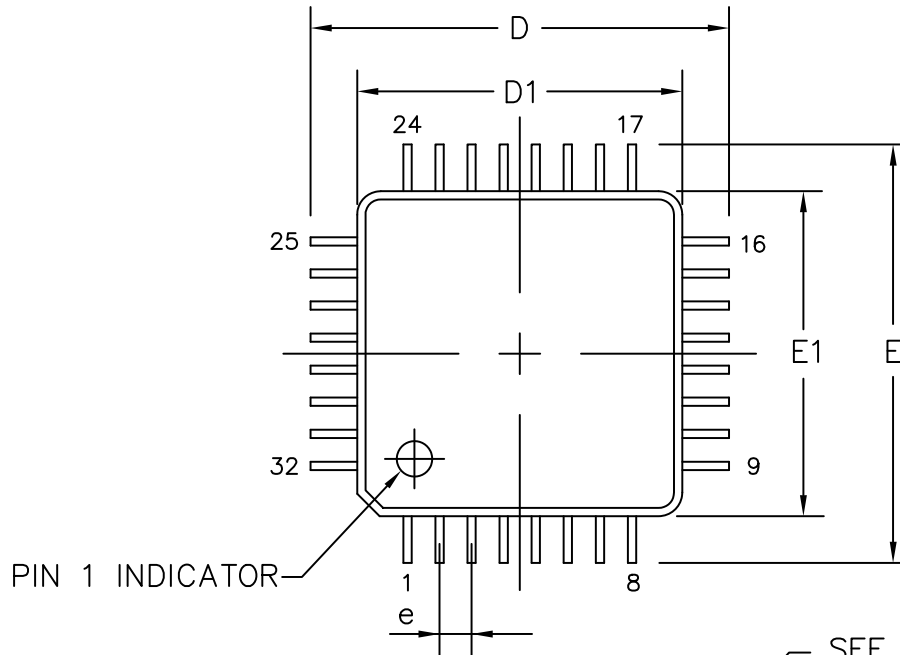

SYMBOL	MIN	NOM	MAX
A	—	—	1.60
A1	0.05	—	0.15
A2	1.35	1.40	1.45
B	0.30	0.37	0.45
B1	0.30	0.35	0.40
C	0.09	—	0.20
C1	0.09	—	0.16
D	9.00 BSC		
D1	7.00 BSC		
E	9.00 BSC		
E1	7.00 BSC		
e	0.80 BSC		
L	0.45	0.60	0.75
L1	1.00		
R1	0.08	—	0.20
α°	11	—	13
β°	0	—	7
γ°	0	—	—

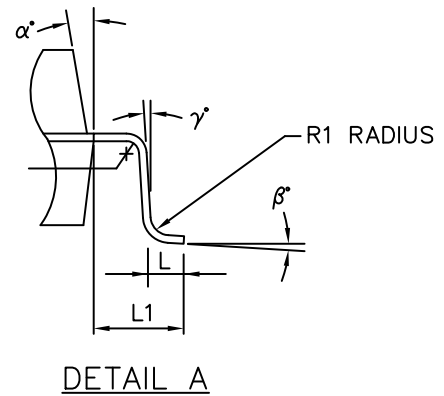
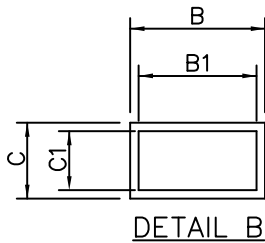
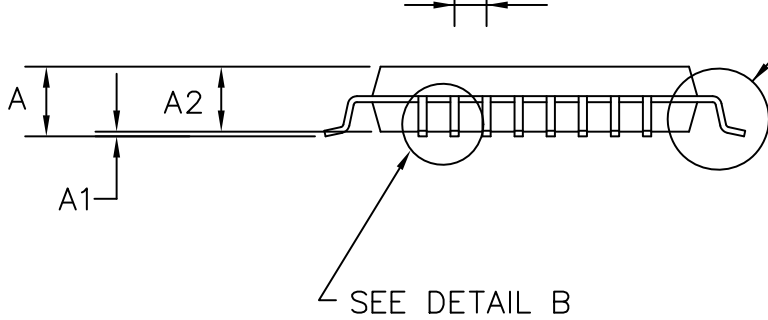

ALL DIMENSIONS IN MM

DOCUMENT NUMBER:	98AON30893E	Electronic versions are uncontrolled except when accessed directly from the Document Repository. Printed versions are uncontrolled except when stamped "CONTROLLED COPY" in red.
DESCRIPTION:	32 LEAD LQFP, 7X7	PAGE 1 OF 1

ON Semiconductor and are trademarks of Semiconductor Components Industries, LLC dba ON Semiconductor or its subsidiaries in the United States and/or other countries. ON Semiconductor reserves the right to make changes without further notice to any products herein. ON Semiconductor makes no warranty, representation or guarantee regarding the suitability of its products for any particular purpose, nor does ON Semiconductor assume any liability arising out of the application or use of any product or circuit, and specifically disclaims any and all liability, including without limitation special, consequential or incidental damages. ON Semiconductor does not convey any license under its patent rights nor the rights of others.

onsemi, **Onsemi**, and other names, marks, and brands are registered and/or common law trademarks of Semiconductor Components Industries, LLC dba "**onsemi**" or its affiliates and/or subsidiaries in the United States and/or other countries. **onsemi** owns the rights to a number of patents, trademarks, copyrights, trade secrets, and other intellectual property. A listing of **onsemi**'s product/patent coverage may be accessed at www.onsemi.com/site/pdf/Patent-Marking.pdf. **onsemi** reserves the right to make changes at any time to any products or information herein, without notice. The information herein is provided "as-is" and **onsemi** makes no warranty, representation or guarantee regarding the accuracy of the information, product features, availability, functionality, or suitability of its products for any particular purpose, nor does **onsemi** assume any liability arising out of the application or use of any product or circuit, and specifically disclaims any and all liability, including without limitation special, consequential or incidental damages. Buyer is responsible for its products and applications using **onsemi** products, including compliance with all laws, regulations and safety requirements or standards, regardless of any support or applications information provided by **onsemi**. "Typical" parameters which may be provided in **onsemi** data sheets and/or specifications can and do vary in different applications and actual performance may vary over time. All operating parameters, including "Typicals" must be validated for each customer application by customer's technical experts. **onsemi** does not convey any license under any of its intellectual property rights nor the rights of others. **onsemi** products are not designed, intended, or authorized for use as a critical component in life support systems or any FDA Class 3 medical devices or medical devices with a same or similar classification in a foreign jurisdiction or any devices intended for implantation in the human body. Should Buyer purchase or use **onsemi** products for any such unintended or unauthorized application, Buyer shall indemnify and hold **onsemi** and its officers, employees, subsidiaries, affiliates, and distributors harmless against all claims, costs, damages, and expenses, and reasonable attorney fees arising out of, directly or indirectly, any claim of personal injury or death associated with such unintended or unauthorized use, even if such claim alleges that **onsemi** was negligent regarding the design or manufacture of the part. **onsemi** is an Equal Opportunity/Affirmative Action Employer. This literature is subject to all applicable copyright laws and is not for resale in any manner.

PUBLICATION ORDERING INFORMATION

LITERATURE FULFILLMENT:

Email Requests to: orderlit@onsemi.com

onsemi Website: www.onsemi.com

TECHNICAL SUPPORT

North American Technical Support:
Voice Mail: 1 800-282-9855 Toll Free USA/Canada
Phone: 011 421 33 790 2910

Europe, Middle East and Africa Technical Support:

Phone: 00421 33 790 2910

For additional information, please contact your local Sales Representative

Mouser Electronics

Authorized Distributor

Click to View Pricing, Inventory, Delivery & Lifecycle Information:

[onsemi:](#)

[MC100EP142FA](#) [MC100EP142FAG](#) [MC100EP142FAR2](#) [MC100EP142FAR2G](#) [MC100EP142MNG](#)
[MC100EP142MNR4G](#)